

**Installation and Maintenance Manual**

**IM 1312**

Group: **WSHP**

Part Number: **910338998**

Date: **January 2021**

**Building Static Pressure Sensor**



# Building Static Pressure Sensor

## Included Parts:

- Building Pressure Sensor
- 3-pin Make Molex plug with (1 each) 12" Blue, White, Green wires

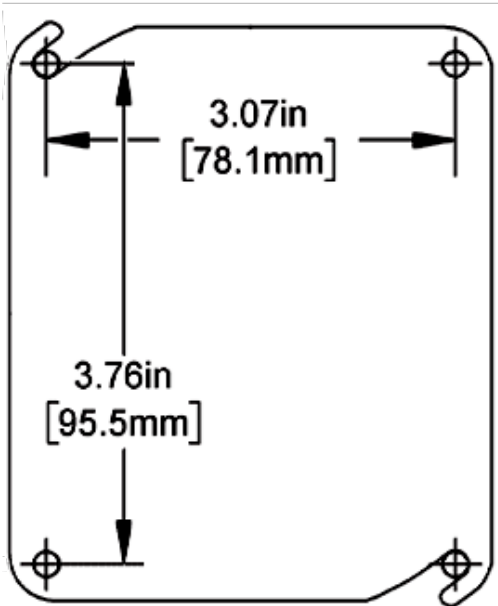
## Additional Required Parts:

- (4) #10 x 3/4" self-tapping sheet metal screws
- 1/4" tubing (1/8" to 3/16" I.D.)
- Outdoor pressure pick-up port
- Indoor/space pressure pick-up port

## Installation

- All wiring must comply with the National Electric Code (NEC) and local codes. Do NOT run any of this device's wiring in the same conduit as other AC power wiring. Tests show that fluctuating and inaccurate signal levels are possible when AC power wiring is present in the same conduit as the signal lines. If you are experiencing any of these difficulties, please contact your Daikin representative.

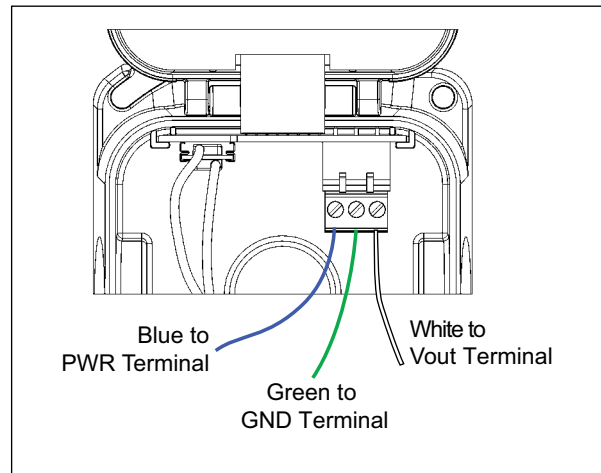
**Figure 1: Drill Holes Mounting Locations**



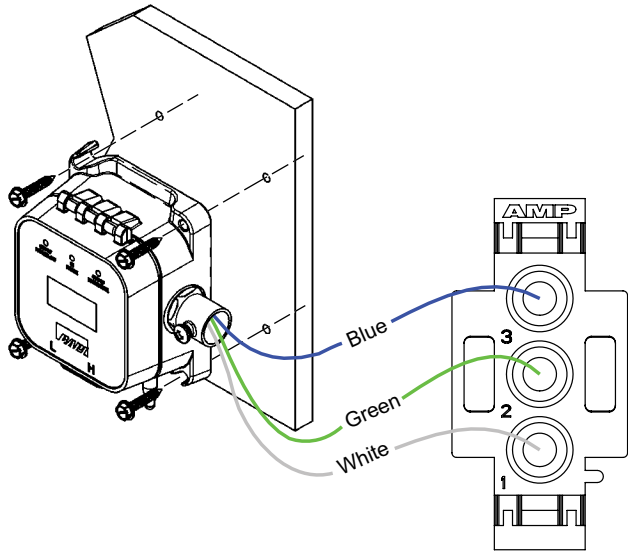
- Use the sensor as a template to locate and mark the mounting holes.

- Locate the field provided outdoor pressure port in a location that is not affected by ambient winds. Locate the indoor/space pressure port where it will not be impacted by doors, operable windows or high moving airflow.
- With the field provided tubing connect the indoor/space pressure port to the high pressure (H) port on the sensor, and the outdoor pressure port to the low pressure (L) port on the sensor.
- Run 3-conductor wire from the sensor location to the unit. Daikin Applied recommends using shielded 22AWG for all connections. Larger gauge wire may be required for runs of greater than 250'.
- Connect the blue, white and green wires to the sensor as follows: See [Figure 2](#).
  - ▶ White to Vout
  - ▶ Green to GND
  - ▶ Blue to PWR

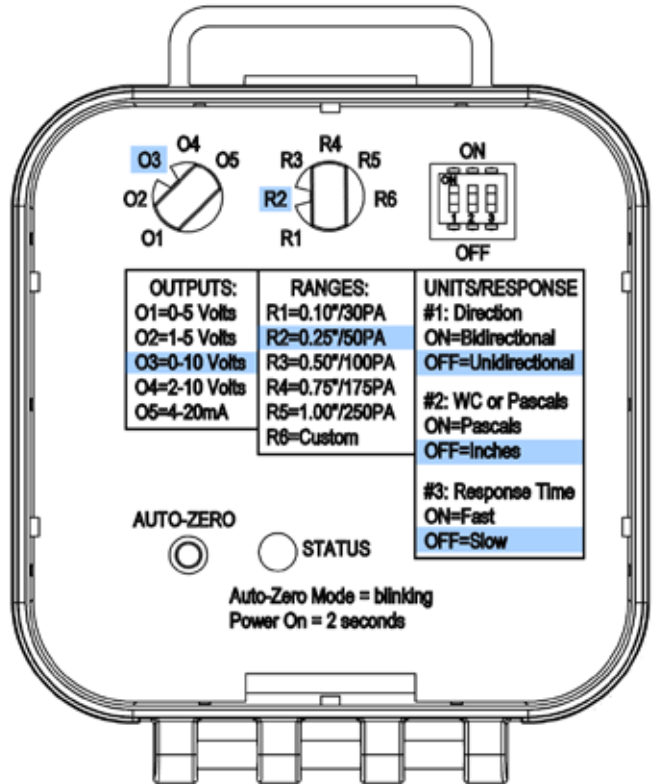
**Figure 2: Connect Wires to Sensor Terminals**



**Figure 3: Sensor and Wiring Assembly**

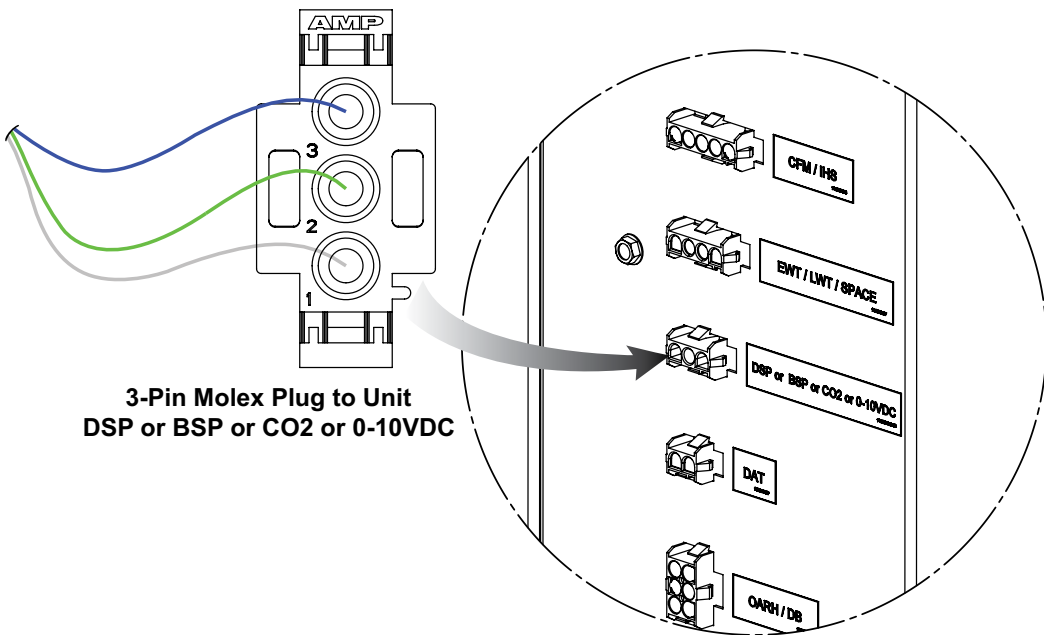


**Figure 4: Sensor Operation Settings**



- The sensor has internal setting options. For proper operation the setting must be as follows: Also refer to Figure 4.
  - ▶ OUTPUTS = 0-10 Volts
  - ▶ RANGES = 0 to 0.25 Inches WC
  - ▶ UNITS/RESPONSE
    - #1: Direction = OFF = Unidirectional
    - #2: WC or Pascals = OFF=Inches
    - #3: Response Time = OFF=Slow
- Connect the field provided tube between the tap and the high pressure (H) port on the sensor.

**Figure 5: Plug 3-Pin Molex Plug to Unit Control Connection, (DSP or BSP or CO2 or 0-10VDC)**



## Programming:

To enable use of this sensor the following configuration points must be changed. Changes can be made through the local user interface or through the ServiceTools software for Microtech® Unit Controllers program on a connected PC. For information on how to use the ServiceTools software, refer to OM 732. The local user interface menu path is shown below.

- To enable Building Static Pressure sensing go to Service > Serv\_Analn > Serv\_Analn\_Config > CFgAnIn16 and change the value from None to BSP. Then go to SET > Set-SensorInstall > FanRstSens and confirm that it is set to 'Inst'.
- To enable fan control based on Building Static pressure go to Set > Set-Unit > FanCntMth and change the value from CONSTANT to BSP.
- The static pressure set-point can be adjusted under Set > Set-Fan > BSPSetPt.

If using the ServiceTools software change the unit configuration as follows:

- To enable Building Static Pressure sensing, go to the 'Configuration' menu and under the 'Inputs' drop down change 'Analog Input 16' to 'BSP'. Confirm that under the 'Sensor Installation' drop down, 'DSP/BSP/CO2/AI Reset' is 'Installed'.
- To enable fan control based on Duct Static pressure go to the 'Configuration' menu and under the 'Fan' dropdown set 'Fan Control Method' to 'BSP'.
- The static pressure setpoint go to the 'Setpoints' menu and under the 'Fan' dropdown adjust the 'Building Static Press' value.

Click the Save button after making changes so they take effect. ServiceTools prompts you to save if you are switching to another screen without saving.

Refer to OM 1308 for additional information on duct static pressure control.



### **Daikin Applied Training and Development**

Now that you have made an investment in modern, efficient Daikin equipment, its care should be a high priority. For training information on all Daikin HVAC products, please visit us at [www.DaikinApplied.com](http://www.DaikinApplied.com) and click on Training, or call 540-248-9646 and ask for the Training Department.

### **Warranty**

All Daikin equipment is sold pursuant to its standard terms and conditions of sale, including Limited Product Warranty. Consult your local Daikin Applied representative for warranty details. Refer to Form 933-430285Y. To find your local Daikin Applied representative, go to [www.DaikinApplied.com](http://www.DaikinApplied.com).

### **Aftermarket Services**

To find your local parts office, visit [www.DaikinApplied.com](http://www.DaikinApplied.com) or call 800-37PARTS (800-377-2787).

To find your local service office, visit [www.DaikinApplied.com](http://www.DaikinApplied.com) or call 800-432-1342.

This document contains the most current product information as of this printing. For the most up-to-date product information, please go to [www.DaikinApplied.com](http://www.DaikinApplied.com).

Products manufactured in an ISO Certified Facility.